

Hold-n-Drive Tools

Kramer Air Tool provides a variety of Hold & Drive components designed specifically for Atlas Copco Tools.

- Dual Flat
- Male hexagon
- Female hexagon



Step #1: How to Order Your Drive Socket .

To order the drive socket, the hex size must be specified in inches. Socket extension lengths (Le) are available in 33mm, 53mm or 73mm.

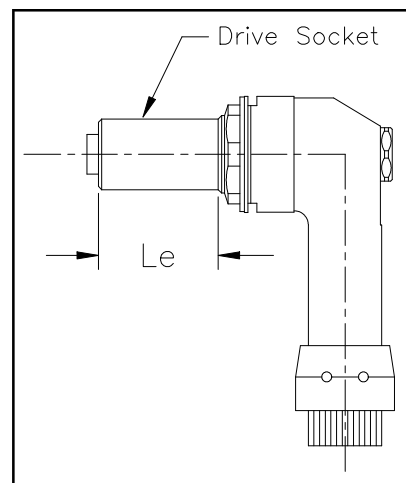
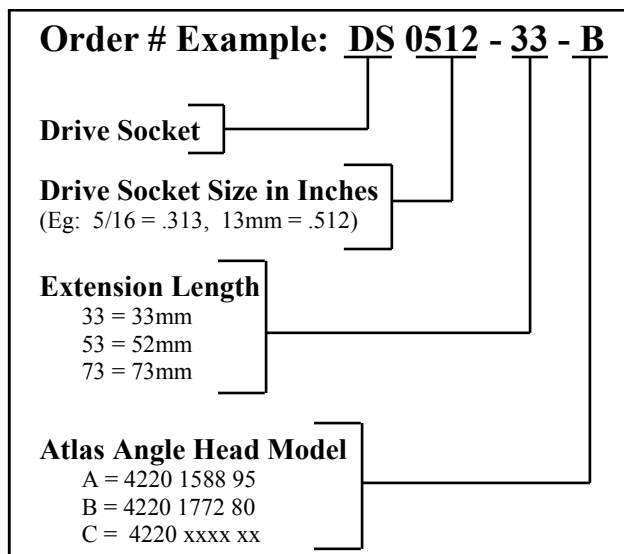

Step #2: Select Your Hold Socket

There are three different hold socket styles available depending upon the type of hold & drive screw being fastened. These fasteners may have a male hexagon end, a male end with dual flats or a female hexagon. Select the appropriate style which matches your specific fastener.

Male Hexagon Hold Socket

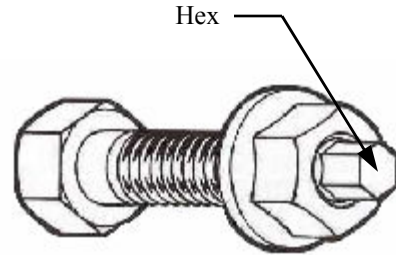
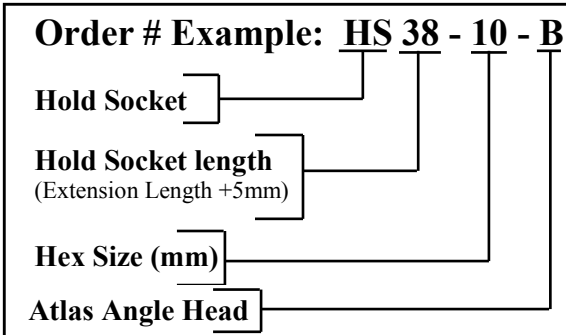

Dual Flat Hold Socket

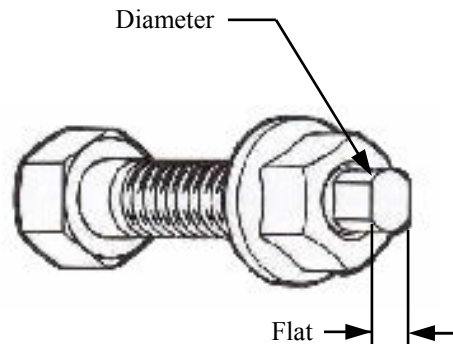
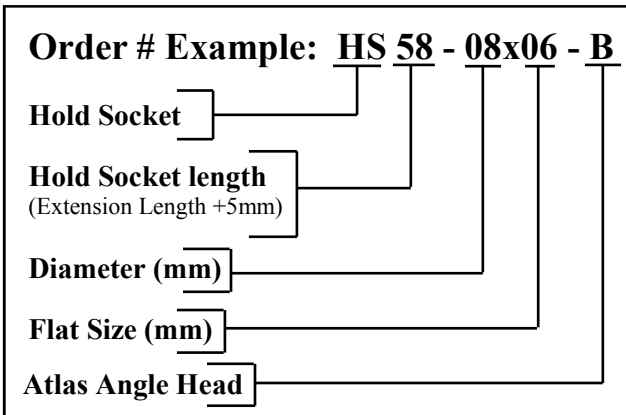

Female Hexagon Hold Socket

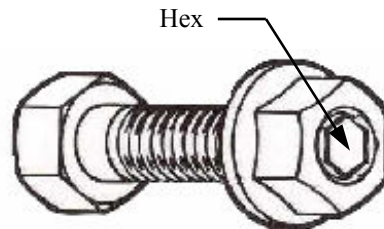
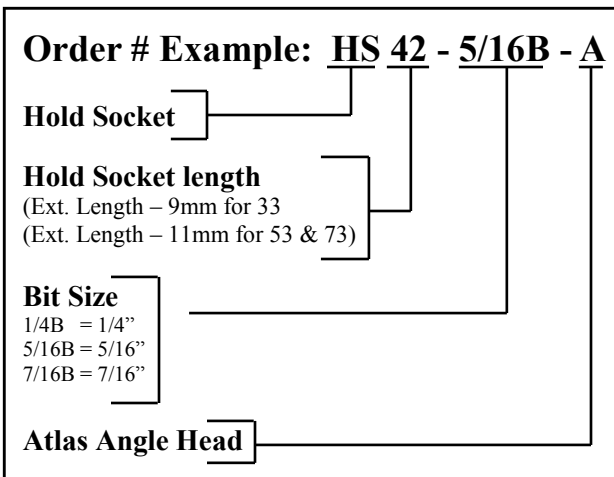

****Bits Sold Separately**